



VF1-75 DC/AC VFD* SYSTEM FOR RUBBER-TIRE-MAN-CARRIERS, LHD, JUMBO-DRILLS AND MINING TRUCKS

*VARIABLE FREQUENCY DRIVE



LHDs (Load Haul Dump)
Scooptram



Jumbo Drills



Mining Truck



Rubber Tire Man Carriers

See videos of our products in operation at www.samincoinc.com

VF1-75 TRAM DRIVE

Part #: A800374M

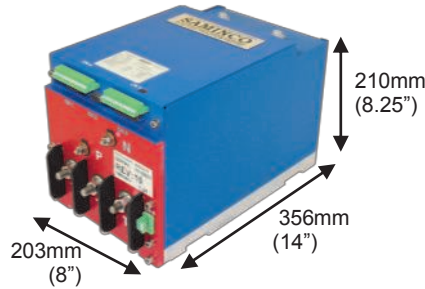

- Regenerative Drive can hold vehicle in stand still position on an incline
- PWM Flux Vector inverter using the latest NPT (non-punch through) IGBT technology
- Variable speed / reversible control
- Flux Vector torque control provides differential traction control for superb cornering
- Turbo Torque provides controlled force minimizing tire spinning
- Rugged, short circuit proof power circuit provides excellent long term reliability
- Multiple control options: standard analog foot switch, radio remote control, master control module
- Proximity ready

PRECHARGE / PUMP START INVERTER

Part #: A800376M

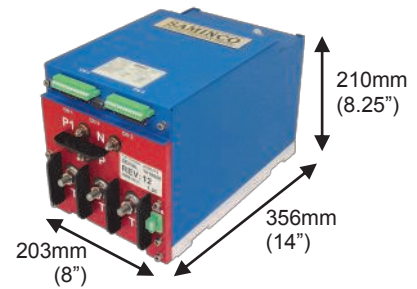

Dual Function:

- Soft charge of 650VDC power Bus DC Bus by-pass contactor
- Pump motor soft start inverter 25kW @ 460VAC programmable pump motor current limit setting
- Whisper Pump reduces decibel level during idle periods, extending exposure time

Specifications	Tram Drive		Pump Drive	
	Rectified Input (DC)	Output (AC)	Rectified Input (DC)	Output (AC)
Rated Power @Rated Volts	72kW @ 650V	75kVA @ 440V	98kW @ 650V	39kVA @ 460V
Frequency range	DC	0 - 125Hz	DC	0-125Hz
Voltage Range	500V - 750V	0 - 525V	500 - 750V	0 - 525V
Amps @ Rated Power	110A	100A(250A peak)	150A	50A (125A peak)

TM1000-nonXP 55kW 1000Nm AC TORQUE TRAM MOTOR

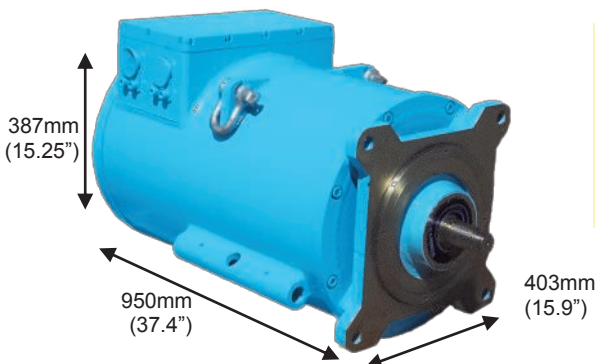
- AC Motor has flexibility to adapt to individual load requirements and is brushless
- AC Motor has substantial increase in torque as compared to competitive motor
- RTD's in windings to monitor motor temperature
- Motors available in non-XP
- Custom manufactured for Saminco
- Saminco encoder has 120°C thermal rating



See your Saminco representative for additional tram motor sizes and for pump motors.

55kW Torque Tram Motor	
Saminco Part #	M6005-067
Peak Torque	1000Nm
Voltage	440
Frequency (Hz)	50
Phase	3
Poles	4
Current (AMPS)	93A
RPM	1485
Duty	1 hour
Enclosure	TENV
Insulation	H
Motor Standard	NEMA
Mounting	Flange
Max Temp	120°C
Weight	590kg (1300 lbs.)

SAMPLE BLOCK DIAGRAM OF LHD OR MINING TRUCK

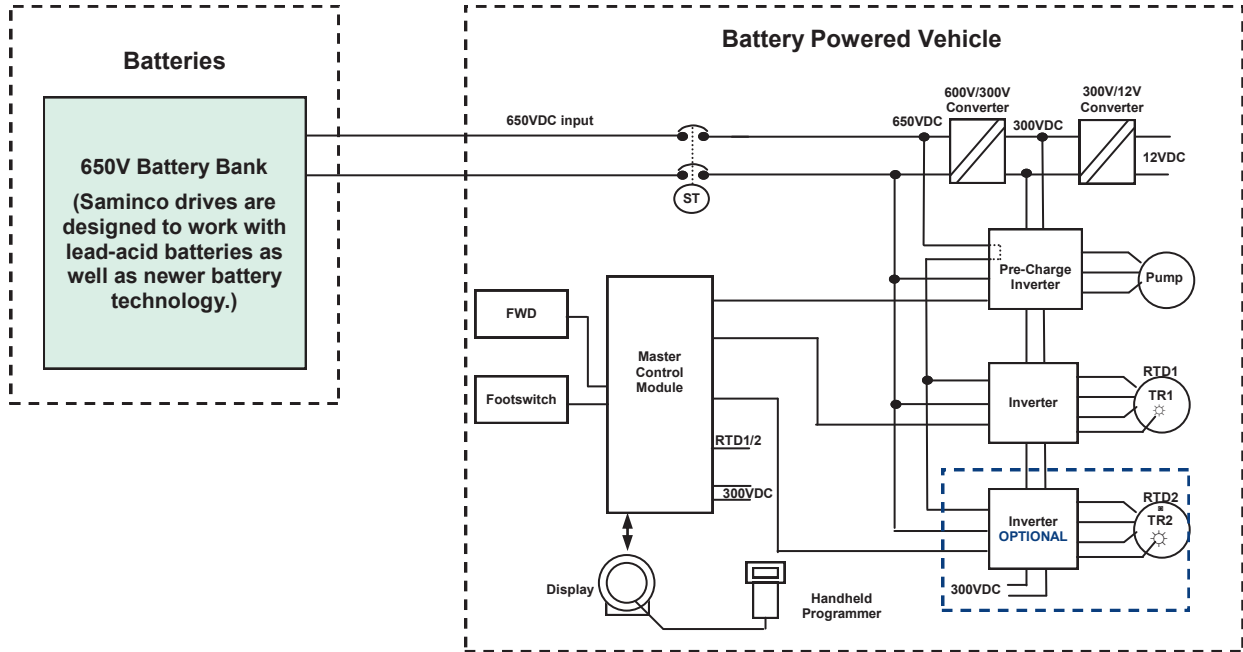

SAMPLE BLOCK DIAGRAM OF JUMBO DRILL

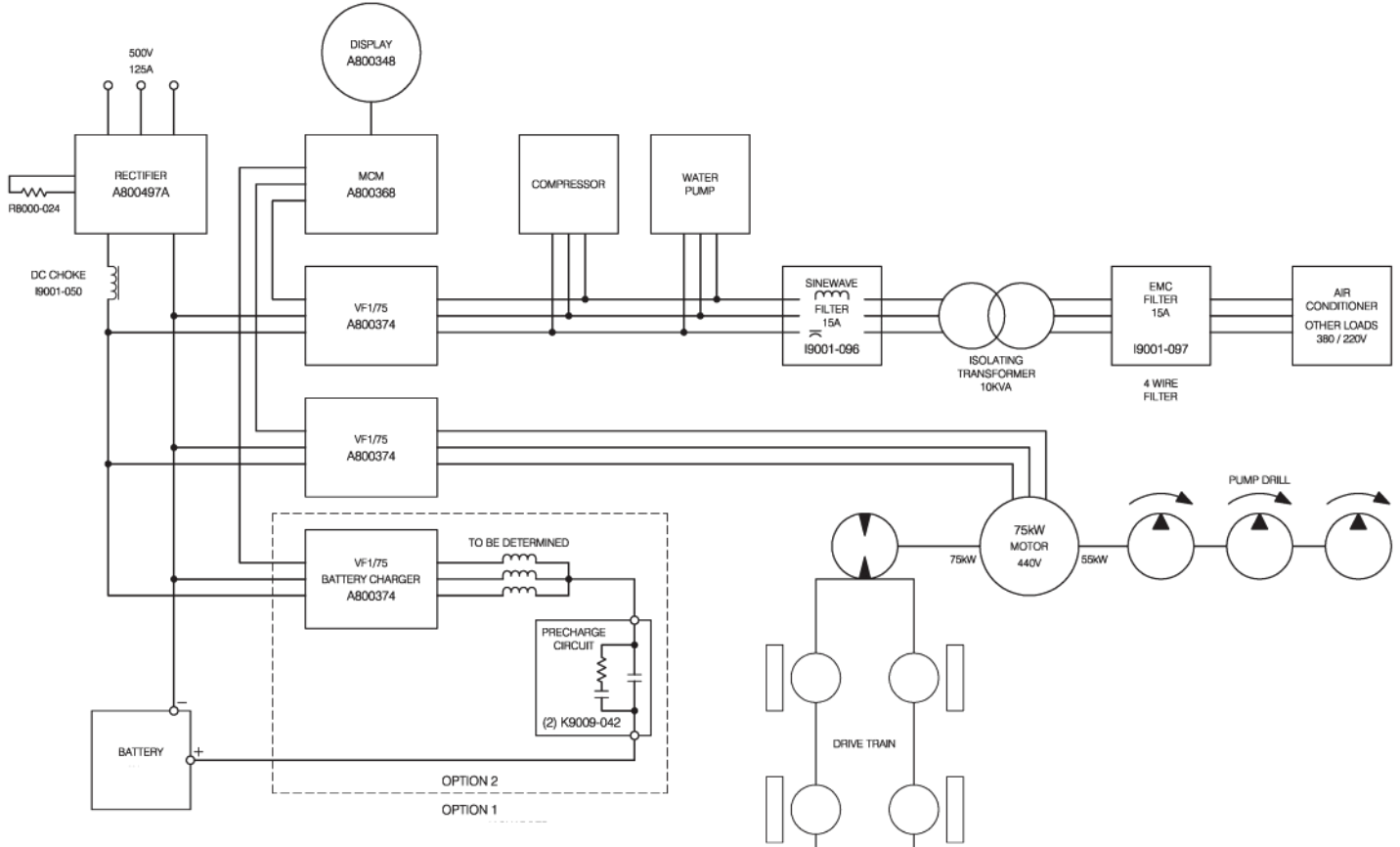

OPTIONS* FOR THE VF1-75 DC/AC VFD Battery System

Part Name	Description	SAMINCO Part Number
VF1-75 Motor Controller	Traction Drive	A800374M
Pre-Charge / Pump Start Inverter	VFD Precharge / Pump	A800376M
Down Chopper	600VDC to 300VDC Down Chopper	A800381
VFD Master Control Module	Master Control Module	A800368
VFD Installation Kit	Installation kit	A800383
Battery Charger	300V DC in, 28V dc 17.8A out	A800329
LU300b	12VDC 300W Light Supply, 90V to 360VDC input	A800966
Diagnostic Display	With programming port	A800348
Handheld Programmer	Allows setting and viewing of system parameters and logs	A800220
Foot Switch	FS400 foot switch assembly	A800498
Capacitor Bank	1620µF / 1200V	A800499
Contactors	225A/750V DC 24V Coil	K9009-056
DCCT	1000A Hall Effect +15V	T9003-018
DCCT Cable	BDI	W6004-188
Cable	25Con Sub-D right angle 36"	W6004-281
TC3 Radio Control System	MSHA APPROVED	
Docking Station	TC3-LHD docking station	A700108
Charger	TC3-LHD charger	A700108
Remote Control	TC3-LHD handheld radio transmitter	A700109
Antenna	900MHz mine duty antenna	A700118
Relay Receiver	RVU AGS ready relay receiver	A700114
Motor and Encoder Parts		
Tram Motor	XV55 - 1000Nm XP torque tram motor	M6005-010
Motor Encoder Assembly	Contains encoder and wheel	M6006-020
Encoder Backplate	Universal backplate	M6006-022
Encoder	Encoder sensor	M6006-023

**Partial list shown. Please see your salesperson for all available options and configurations

ADDITIONAL BENEFITS OF THE SYSTEM

BATTERY MANAGEMENT SYSTEM

Able to monitor battery levels from display
 "Low Battery" warning

- Automatic slow down of some functions
- Torque retained, speed reduced to conserve energy
- Enables vehicle limited time to return to power center for recharging

ZERO EMISSIONS

Fully electric - eliminates DPM (Diesel Particulate Matter)
 Reduces ventilation requirements and costs
 No need to haul and store diesel fuel underground
 allowable exposure time

PROXIMITY READY

Variable Frequency Drive accurately controls torque, speed and direction allowing for controlled slow down (Warning Zone) or immediate shut down (Stop Zone)
 Works with most Proximity Detection Systems currently on the market

SAMINCO'S BATTERY CHARGER

As part of a complete system, Saminco has also developed a battery charger. The battery charger is 200A / 640V, complies with international EMI and Harmonic Distortion levels.



Saminco system in operation



Saminco Battery Charger

Visit our website at www.samincoinc.com or email us at sales@samincoinc.com



FLORIDA

Headquarters
 10030 Amberwood Rd.
 Fort Myers, FL 33913
 PH: 239-561-1561
 FAX: 239-561-1502

WEST VIRGINIA

Service Branch
 517 Virginia Ave.
 Huntington, WV 25701
 PH: 304-523-4700
 FAX: 304-523-4039

COLORADO

Service Branch
 Cedaredge, CO
 PH: 940-623-0000

SOUTH CAROLINA

Service Branch
 Anderson, SC
 PH: 304-654-9054

INTERNATIONAL LOCATIONS:

Boksburg, South Africa PH: +11 397 6026
Australia PH: +86 15140090694
China PH: +61 2 9899 6857
Poland