



VF SERIES BATTERY VFD* SYSTEMS

AVAILABLE IN 128V-240V

FOR SCOOPS, SHIELD/ BATTERY HAULERS,
AND MANTRIPS

*VARIABLE FREQUENCY DRIVE

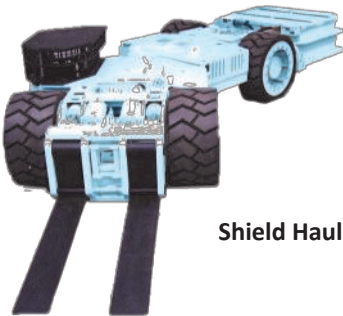

Shield Haulers



Scoops

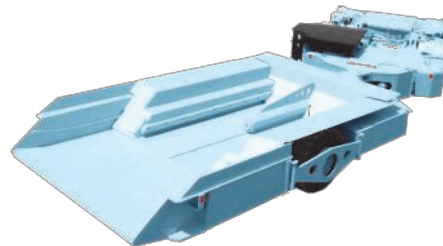

Battery Hauler

See videos of our products in operation at www.samincoinc.com

MODULE SPECIFICATIONS

Tram Drive
(for large motors)
VF -1200 series

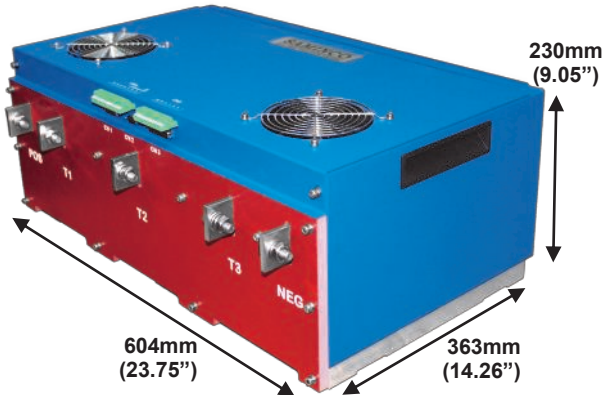

Tram Drive
(for medium motors)
VF -700 series

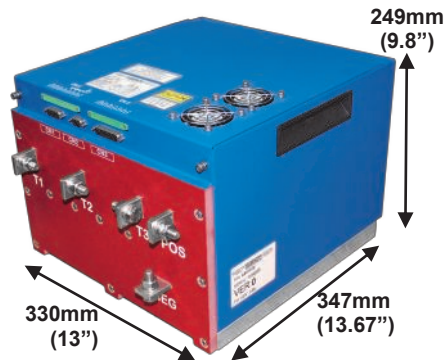

Pump Drive
VF -400 series

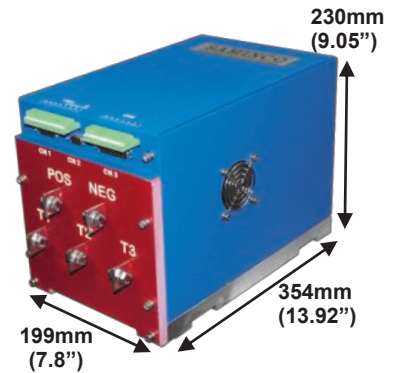

Specifications	Part Name	System Description	Rated Power				
			Power @ Rated Volts	Frequency Range	Voltage Range	Amps @ Rated Power	
Tram Drive (for large motors)	VF1-1200	128V	INPUT	62kW @ 128VDC	DC	100 - 150VDC	485A
			OUTPUT	58kW @ 80VAC	0 - 125Hz	0 - 100VAC	495A / 1200A peak
	VF2-1200	240V	INPUT	105kW @ 240V	DC	160 - 300V	440A
			OUTPUT	100kW @ 138V	0-125Hz	0 - 170V	500A / 1200A peak
Tram Drive (for medium motors)	VF1-700	128V	INPUT	30kW @ 128VDC	DC	100 - 150VDC	235A
			OUTPUT	39kW @ 80VAC	0 - 120Hz	0 to V in x 0.7	285A / 700A peak
	VF2-700	240V	INPUT	70kW @ 240V	DC	160 - 300V	290A
			OUTPUT	68kVA @ 138V	0-125Hz	0 to V in x 0.7	285A / 700A peak
Pump Drive	VF1-400	128V	INPUT	23kW	DC	100 - 150VDC	180A
			OUTPUT	21kW @ 70VAC	0 - 125Hz	0 - 100VAC	200A / 400A peak
	VF2-400	240V	INPUT	43kW @ 240V	DC	160 - 300V	180A
			OUTPUT	41kW @ 138V	0-125Hz	0 - 170V	200A / 400A peak

BENEFITS

THE BATTERY / AC VFD SYSTEM

- Easily retrofitted into current equipment
- Failsafe– motor rotation will stop if drive fails
- Low maintenance with AC motor
- No need to replace batteries: will work with lead-acid batteries as well as new battery technology

WITH TURBO TORQUE™ TRACTION DRIVE

- Better stall torque and higher top speed than the equivalent 36kW (50HP) DC drive
- Speed governor
- Effective Regenerative braking; minimizes the use of mechanical brakes

WITH WHISPER PUMP™ ON-DEMAND HYDRAULIC PUMP DRIVE

- Reduced noise in pump idle mode, from 80 to 70 decibels
- Significant battery energy reduction during idle
- Smoother steering at pump idle

BATTERY MANAGEMENT SYSTEM

- Able to monitor battery levels from display
- "Low Battery" warning
 - Automatic slow down of some functions
 - Torque retained, speed reduced to conserve energy
 - Enables vehicle limited time to return to power center for recharging

MOTORS

- Saminco AC motors are dual voltage for 128V and 240V (both traction and pump motors)
- Robust all steel "mine-duty" round barrel construction
- Rotors are a copper alloy fabricated design for high efficiency, less slip and lower rotor losses (compared to equivalent aluminum die-cast rotors)
- Saminco encoder has 120° thermal rating
- Motor has flexibility to adapt to individual load requirements

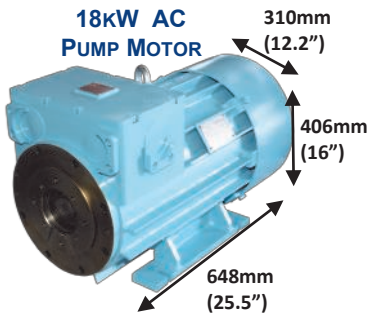

Pictured: Copper bar rotors

	55kW AC Traction Motor	80kW Traction Motor	18kW AC Pump Motor
Saminco Part #	M6005-016-1	M6005-036	M6005-019
kW	55kW	80kW	18kW-Continuous 34kW - 1 hour
Peak Torque	1000Nm	1500Nm	-
Volts (from inverter)	80 / 138 AC	160 / 277 AC	80 / 138 AC
Frequency (Hz)	50	50	60
Phase	3	3	3
Current (AMPS)	495 / 280	390 / 225	175 / 101
RPM	1478	1481	1763
Enclosure	TEXP	TEXP	TEXP-fan cooled-IP55
Insulation	H	H	H
Cooling	Non-ventilated	Non-ventilated	Ventilated
Max Temp	120°C	120°C	120°C
Weight	800kg (1764 lbs.)	800kg (1764 lbs.)	260kg (573 lbs.)
MSHA ASSY #	27450 B	33850 Aa	29400 Aa
MSHA Approval #	07-JA050005-0	07-JA130001-0	07-JA110005-0

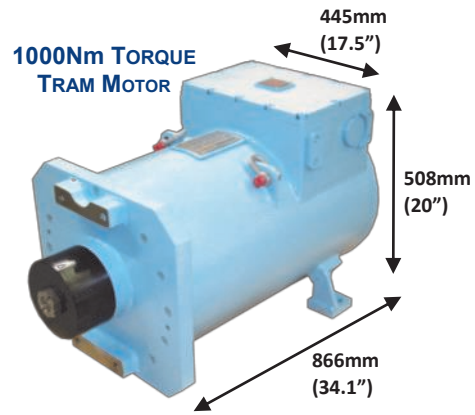
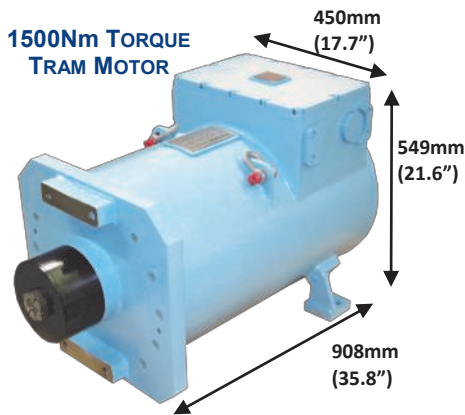

SAMPLE BLOCK DIAGRAM OF 240V BATTERY / AC VFD SYSTEM

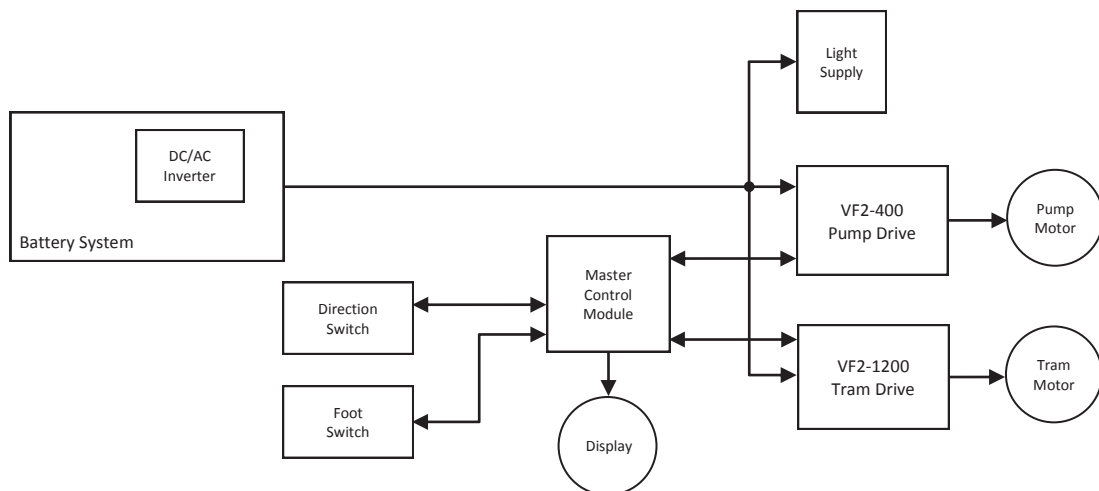

OPTIONS* FOR THE VF SERIES

Part Name	Description	SAMINCO Part Number
128V System	128V Battery / AC VFD System - single motor	A800659
240V System	240V Battery / AC VFD System - single motor	A800786
System specific parts		
VF1-1200	128VDC Variable Frequency Drive precharge / tram	A800682
VF1-700	120VDC 300A Variable Frequency Drive	A801018
VF1-400	128VDC Variable Frequency Drive precharge / pump	A800679
VFD Master Control Module	128V VFD Master Control Module	A800468
VF2-1200	240VDC Variable Frequency Drive precharge / tram	A800782
VH2-700	240VDC 300A Variable Frequency Drive	A801019
VF2-400	240VDC Variable Frequency Drive precharge / pump	A800781
VFD Master Control Module	240V VFD Master Control Module	A800368
Parts available for both systems		
LU300b	12VDC 300W Light Supply, 90V to 360VDC input	A800966
Diagnostic Display	With programming port - aluminum enclosure	A800348
Diagnostic Display	With programming port - steel enclosure	A800406
Foot Switch	SR300 foot switch assembly	A800281
Panic Switch	PS300 panic switch	A800190
DCCT	1000A HALL EFFECT + - 15V	T9003-018
Cable 4CON	22AWG 30 ft, Diagnostic out xp box	W6004-181
Cable 25CON	25CON Sub-D 72	W6004-184
DCCT Cable	DCCT Cable for BDI	W6004-188
Base Plate	Base plate for tram and pump drives	Y9005300
Clamp	Clamp Steel (Black Oxide)	Y9007163
Handheld Programmer	Universal Drive Programmer	A800220-1
Battery Fuel Gauge	Battery Fuel Gauge	A600104
TC3 Radio Remote Control		
TC3 Remote Control	Radio remote control	A700109
TC3 Charger	With power cord	A700108
TC3 Docking Station	Docking Station	A700107
TC3 Can Receiver	CanBus Proximity - Radio RVU	A700110
TC3 Relay Receiver	RVU AGS Ready	A700114
Antenna	900MHz mine duty	A700118
Motors and Encoders		
1000Nm Tram Motor	55kW 3Phase 50Hz 80 -138V AC	M6005-016-1
1500Nm Tram Motor	80kW 3Phase 50Hz 160 - 277V AC	M6005-036
Pump Motor	18kW 3Phase 60Hz 80 -138V AC	M6005-019
Motor Encoder Assembly	Contains encoder and wheel	M6006-020
Encoder Backplate	Universal backplate	M6006-022
Encoder	Encoder sensor	M6006-023

*Partial list shown. See your sales representative for all available options and configurations.

Visit our website at www.samincoinc.com or email us at sales@samincoinc.com

FLORIDA
Headquarters

10030 Amberwood Rd.
 Fort Myers, FL 33913
 PH: 239-561-1561
 FAX: 239-561-1502

WEST VIRGINIA
Service Branch

517 Virginia Ave.
 Huntington, WV 25701
 PH: 304-523-4700
 FAX: 304-523-4039

COLORADO
Service Branch

Cedaredge, CO
 PH: 940-623-0000

SOUTH CAROLINA
Service Branch

Anderson, SC
 PH: 304-654-9054

INTERNATIONAL LOCATIONS:

Boksburg, South Africa PH: +11 397 6026
Australia PH: +86 15140090694
China PH: +61 2 9899 6857
Poland