

DIESEL-ELECTRIC SHUTTLE CAR PROPULSION SYSTEM BLOCK DIAGRAM

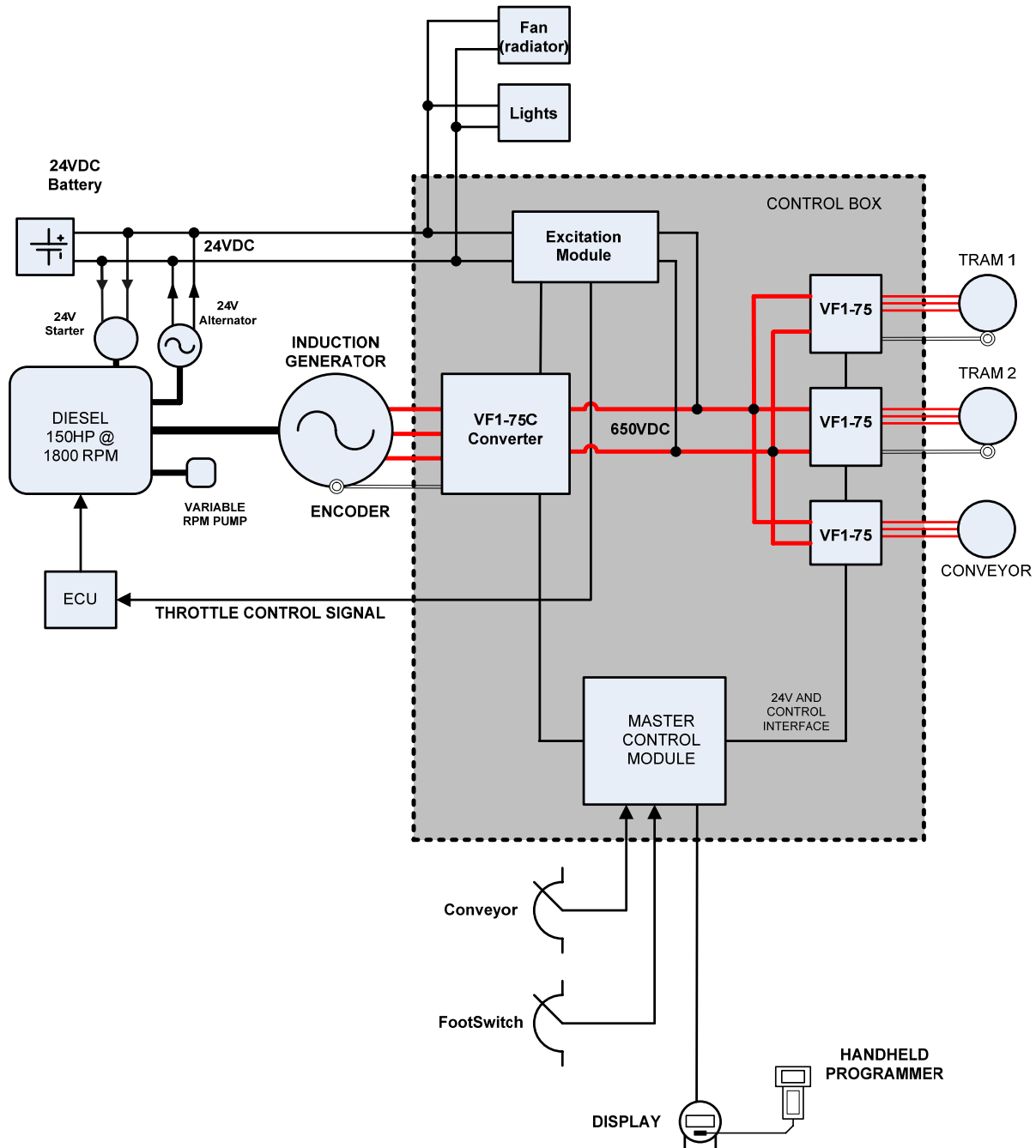

TWO OPERATIONAL QUADRANTS OF BI-DIRECTIONAL DC/AC CONVERTER ARE USED IN TRACTION MOTOR CONTROLLER FOR MOTORING OR BRAKING

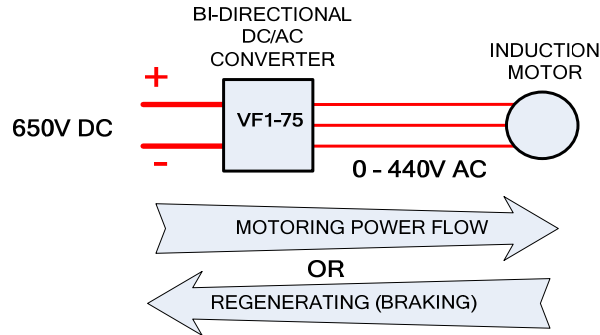

THE SAME BI-DIRECTIONAL DC/AC CONVERTER CAN BE USED AS GENERATOR CONVERTER

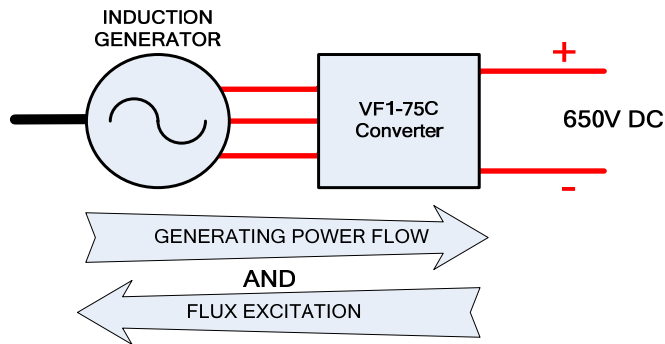

COMBINATION OF DC/AC CONVERTERS USED AS GENERATOR CONVERTER AND TRACTION MOTOR CONTROLLER

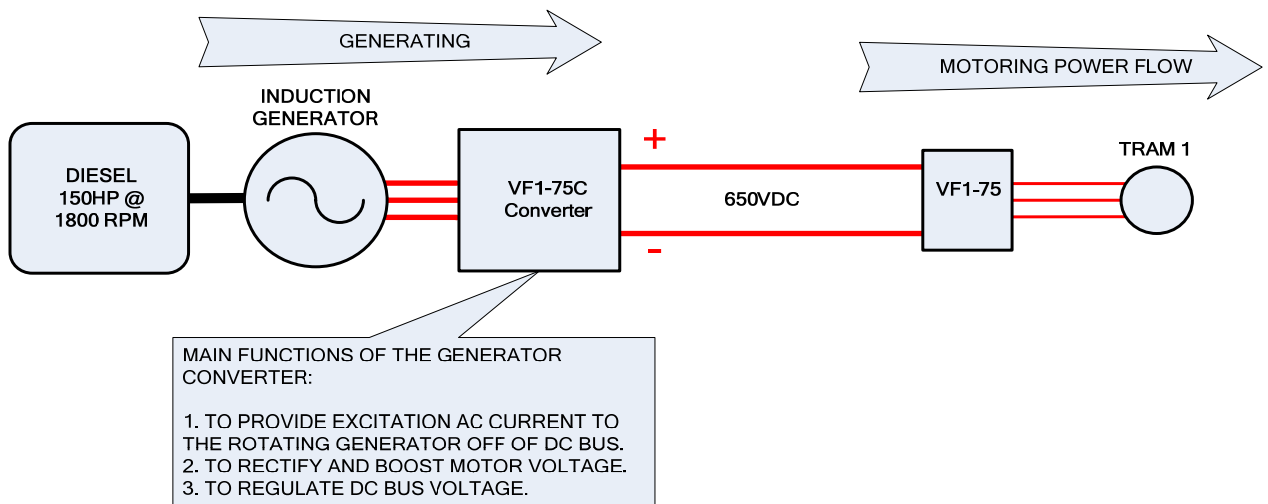

DIESEL-ELECTRIC SHUTTLE CAR START SEQUENCE

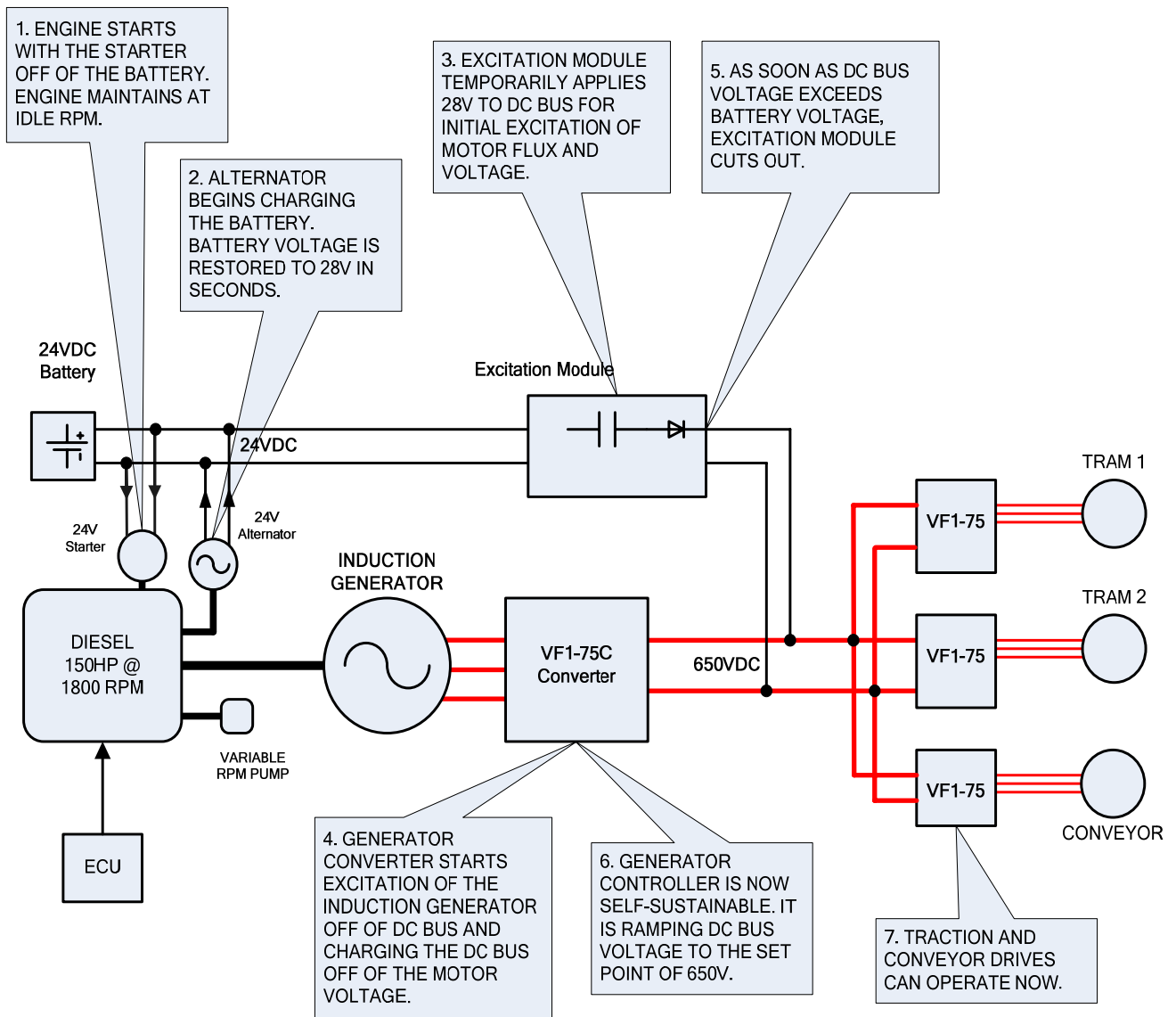

DIESEL-ELECTRIC SHUTTLE CAR CONTROL STRATEGY

