

Q800 Series

Digital DC/DC Locomotive Controller

20 - 40HP at 120VDC 40 - 80HP at 250VDC

SAMINCO

ELECTRIC TRACTION DRIVES

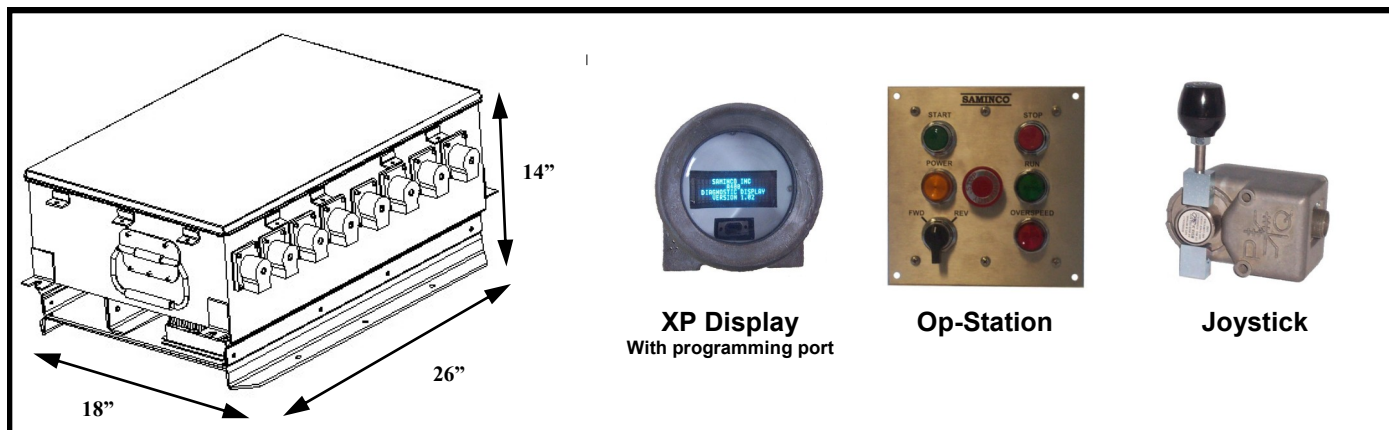

Typical Q800 for Trolley Application

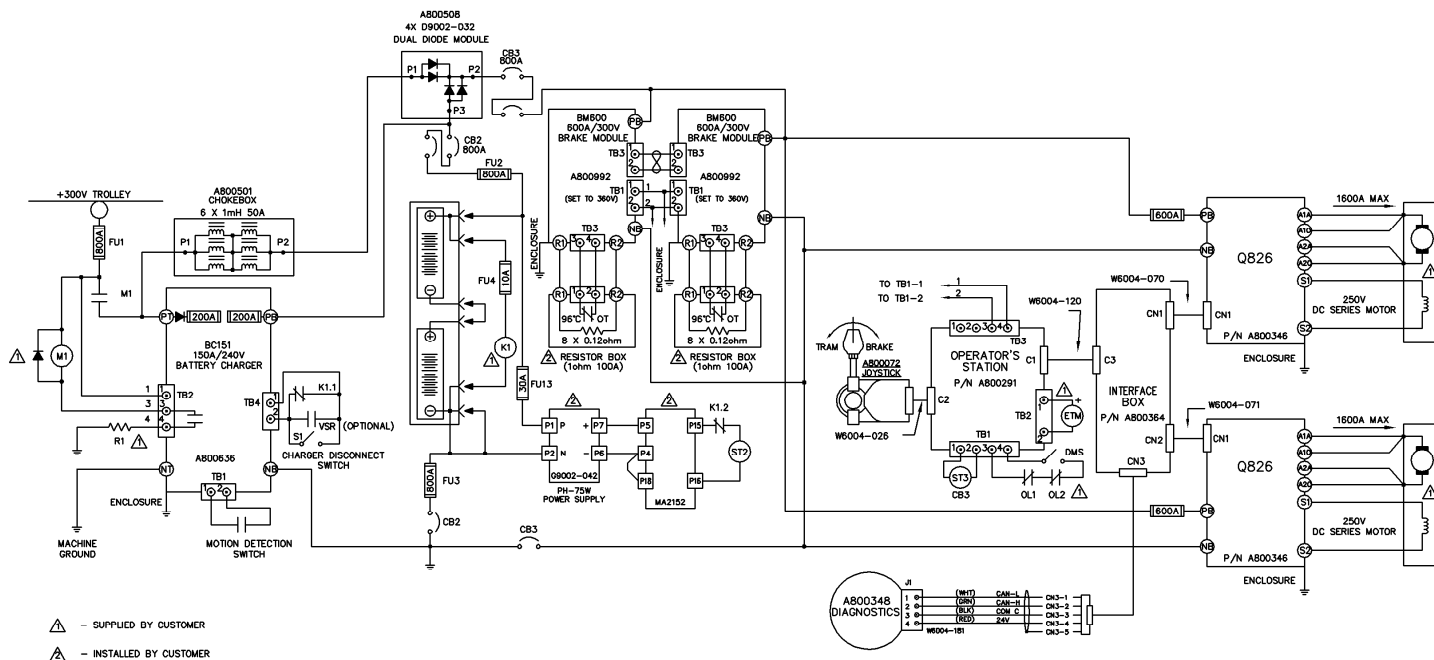

Model	Part Number	Description	Input V	Output Power
Q812	A800345	Single Motor 40HP 128V	80 - 160VDC	32kW (250A @ 128VDC)
Q820	A800359	Dual Motor 20HP 128V	80 - 160VDC	2x 16kW (2x 125A @ 128VDC)
Q826	A800346	Single Motor 80HP 240V	180 - 360VDC	60kW (250A @ 240VDC)
Q821	A800314	Dual Motor 40HP 240V	180 - 360VDC	2x 30kW (2x 125A @ 240VDC)