



DC/AC VFD System for Shuttle Cars



Performance Advantages

Load Sharing Tram Motors
 Smooth and Reliable Electrical Braking
 Variable Speed / Reversible Conveyor Control
 Approximately two times more power can be delivered to the Shuttle Car via the 550VDC Cable

DC cable more reliable
 Can get more cable on the reel
 DC cable quicker/easier to troubleshoot and repair
 Longer lengths allowed by MSHA – 850 feet of #2/0 is common
 Less Trailing Cable heat - up to 75 percent less heat than 250VDC Trailing Cables

Trailing Cable Advantages

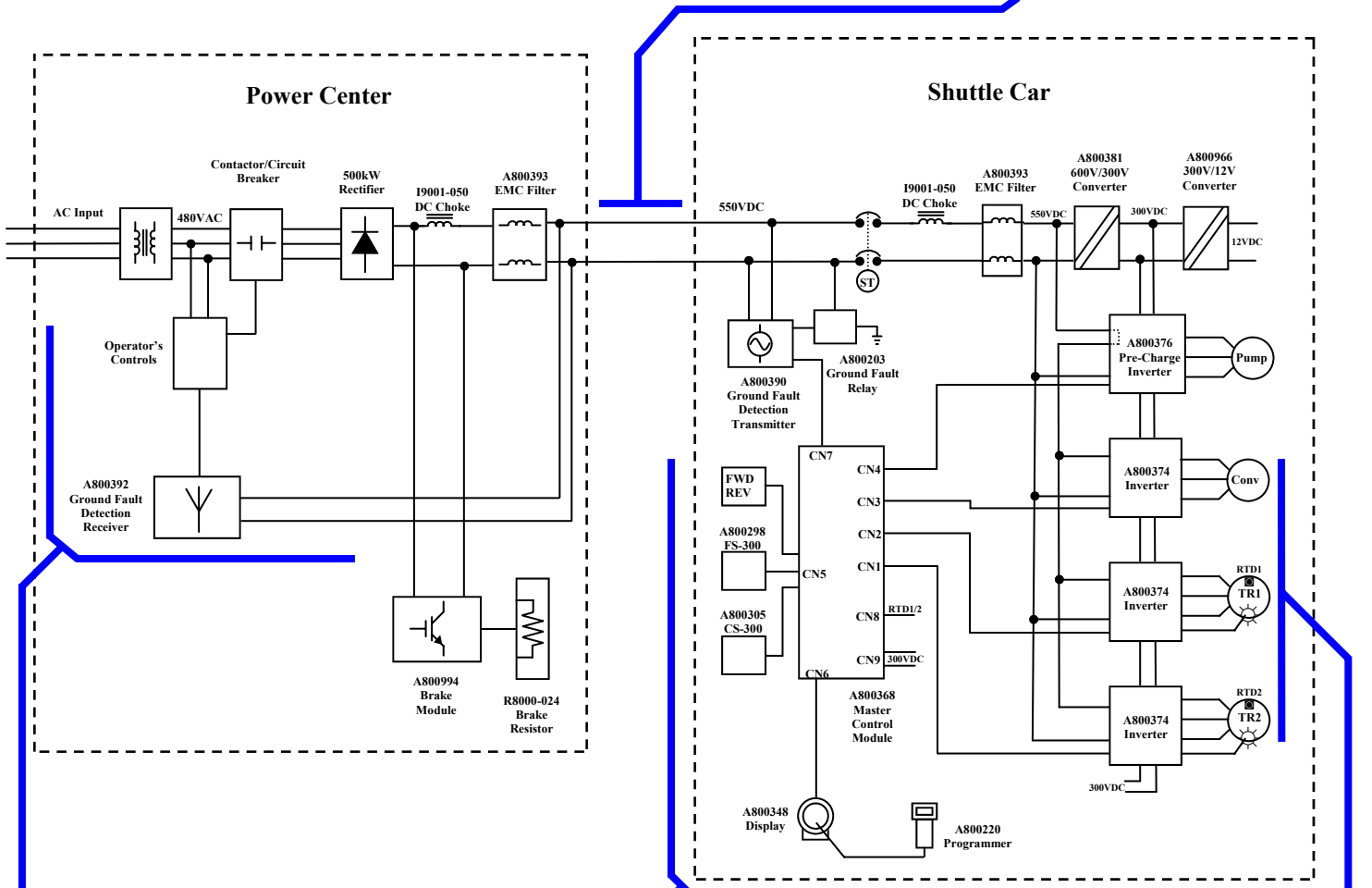

Safety Advantages

Detects Trailing Cable Faults
 No live open wires on ground with cut cable
 Motor and Drive Ground Faults detected immediately
 Power center *instantly* shuts down in case of cable break

AC Motor Advantages

Substantial increase in torque as compared to competitive motor
 RTD's in windings to monitor motor temperature
 Fabricated Copper Rotor
 No Brushes

Shuttle Car Controller Advantages

Less heat in XP box
 No front end losses
 System Programming via port in display - no need to open XP Enclosure