

BM-300
DC Braking Module
300A/320VDC

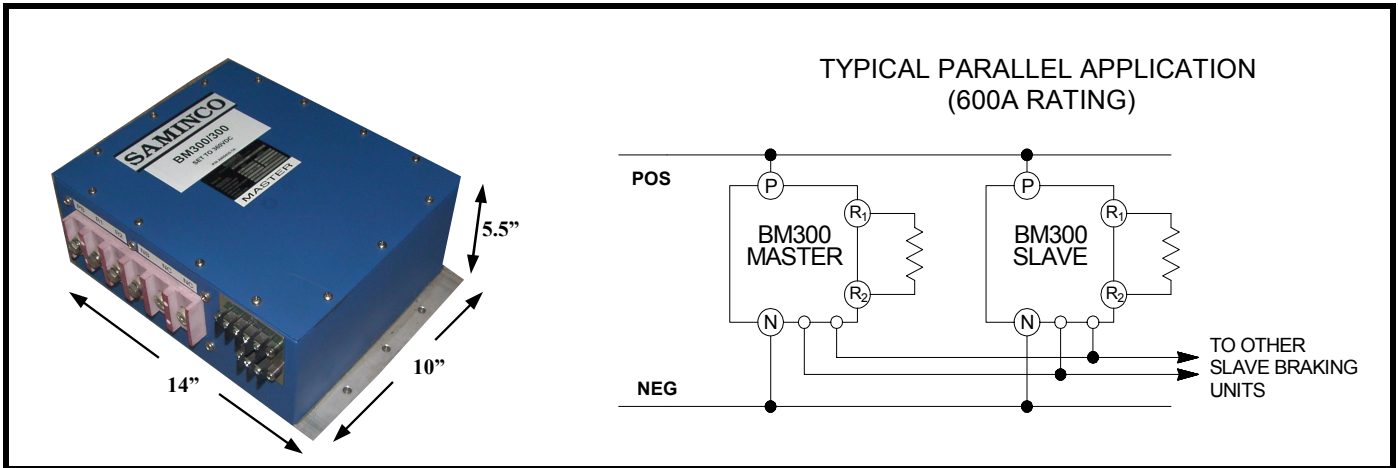

- Absorbs high voltage surges on DC voltage supplies from 120V to 320V due to regenerative braking of DC or AC traction drives
- Capable of dumping up to 300A into braking resistor
- 10% duty cycle (for example, 6 seconds on, every 60 seconds)
- Contains provision for resistor overtemperature protection via resistor OT sensor
- Compact, single enclosure houses all components, including internal power supplies
- Up to 5 modules can be operated in parallel to absorb up to 1500A

<u>SAMINCO Part Number:</u>	A800435-1
<u>SPECIFICATIONS:</u>	
Input Voltage:	120V to 360V nominal
Threshold Braking Voltage:	Adjustable 150V to 400V
Maximum Current:	300A (per module)
Duty Cycle:	10% (e.g. 6 seconds on, every 60 seconds)
Braking Resistor Rating:	150V Threshold: 0.5ohm, 100A continuous 360V Threshold: 1.2ohm, 100A continuous

Saminco North
 4500 State Rt. 152 Lavalette, WV 25535
 Phone: (304) 523-4700 Fax: (304) 523-4039

Saminco
 10030 Amberwood Road Fort Myers, FL 33910
 Phone: (239) 561-1561 Fax: (239) 561-1502

WWW.SAMINCOINC.COM